

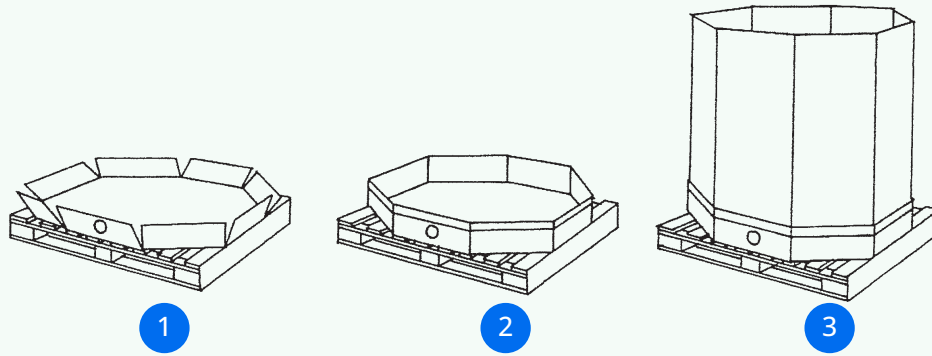

Tote Solutions Ltd.

# Liqui-Trip Container Assembly



- 1 Make up the bottom tray by folding the flaps inwards and securing with sticky tape on each joint.
- 2 Place on pallet with the discharge hole adjacent to an open edge of the pallet.
- 3 Open out the inner sleeve to form the octagon shape and stand it inside the bottom tray ensuring that the discharge holes are lined up.

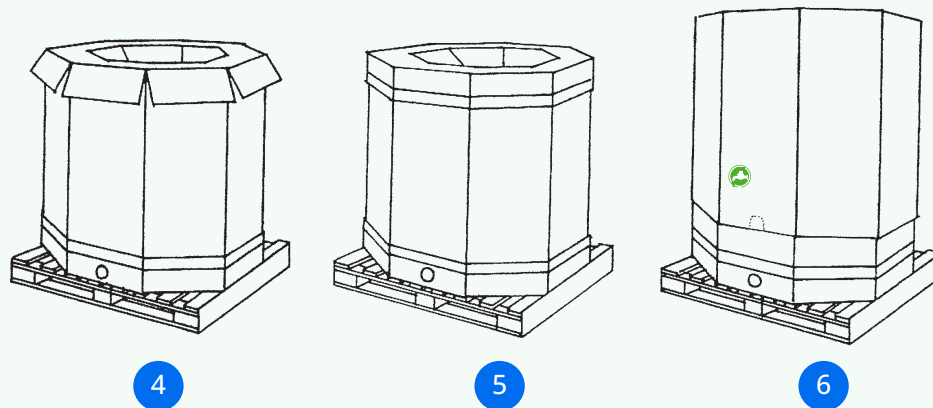

- 4 Make up the top tray in the same manner as the bottom tray.
- 5 Place on the top of the inner sleeve.
- 6 Open out the outer sleeve to form the octagon shape and place over the container, pushing it right down to the pallet once again ensuring that the perforated cut out, lines up with the discharge hole.

## Prepare for Filling Instructions

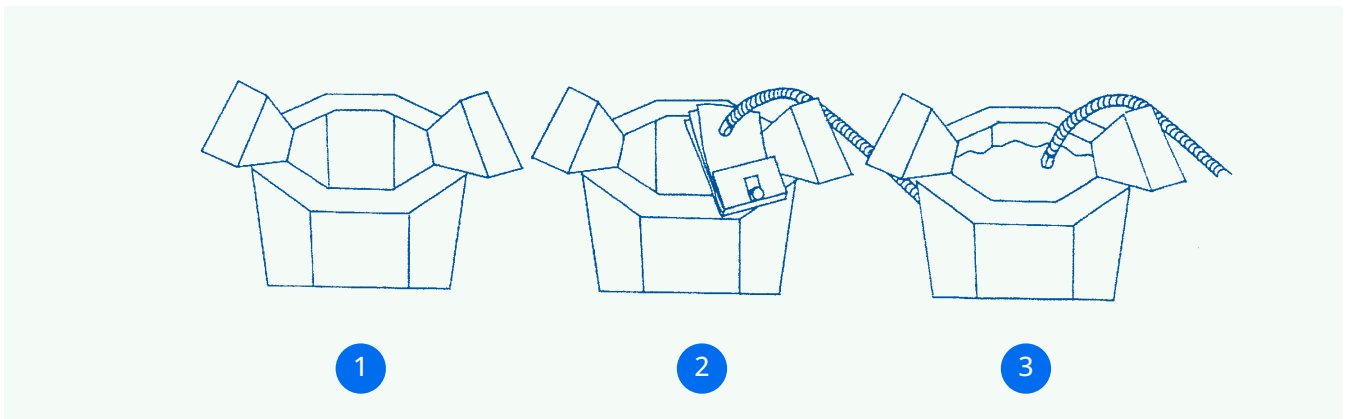

- 1 Attach filling pipe to liner cassette fitment.
- 2 Drop filling pipe and liner cassette into the container.
- 3 Ensure cassette is located to the back of the container and the decant fitment engages into the discharge hole and base tray.

## Prepare for Shipping

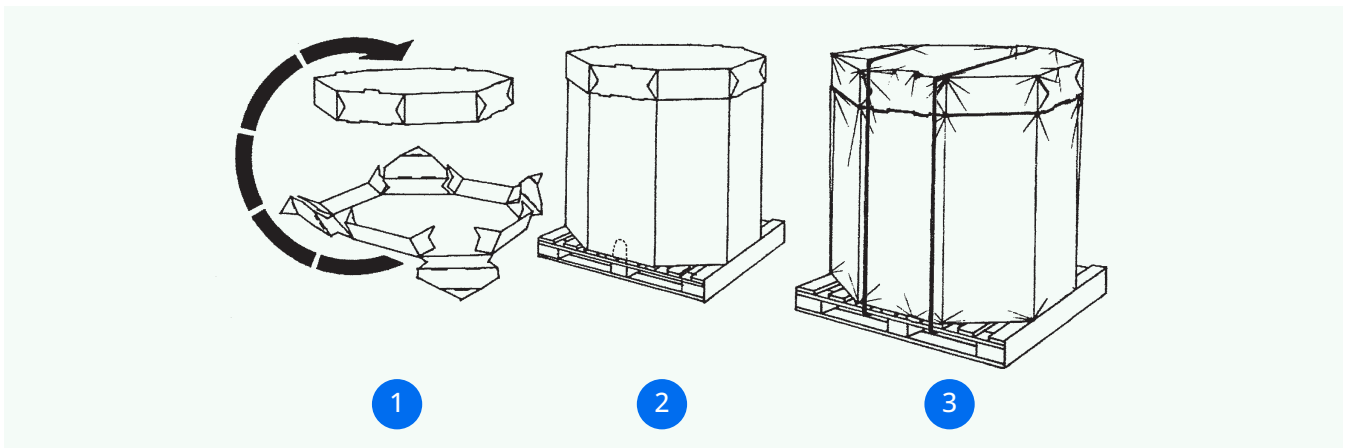

- 1 Make up the lid by folding all creases and locating the tabs in the corresponding slots. Place on top of Liqui-Trip Container.
- 2 Cover with weather proof shroud if required.
- 3 Ensure Liqui-Trip Container is banded twice to pallet prior to moving.

