



Tote Solutions Ltd.

Liqui-Trip



THE SAFE AND STRONG ONE TRIP ANSWER FOR THE TRANSPORTATION OF LIQUIDS

When looking for efficient economy...There is only one-way to go. Liqui-Trip is the safe and strong one-way trip answer for the transportation of liquids where the recovery of packaging is undesirable or uneconomic.

This 1000 Litre liquid container is manufactured in multi-layer reinforced corrugated board with a wooden pallet, all materials are recyclable and environmentally friendly. Liqui-Trip is supplied flat packed to reduce the storage and transportation cost of empty units and can be readily and quickly assembled for use. The combined liner and cassette ensure an easy and efficient fill and decant. The unit can be safely stacked 3 high and a waterproof cover is provided for weather protection.

This one-way environmentally friendly intermediate bulk container is available with liquid liners, valves and other accessories to provide a cost effective, robust and recyclable packaging solution for the food, beverage and specialty chemicals industries.

Liqui-Trip comfortably carries **1000 litres**, with easy filling and decanting.

Liqui-Trip Container Assembly

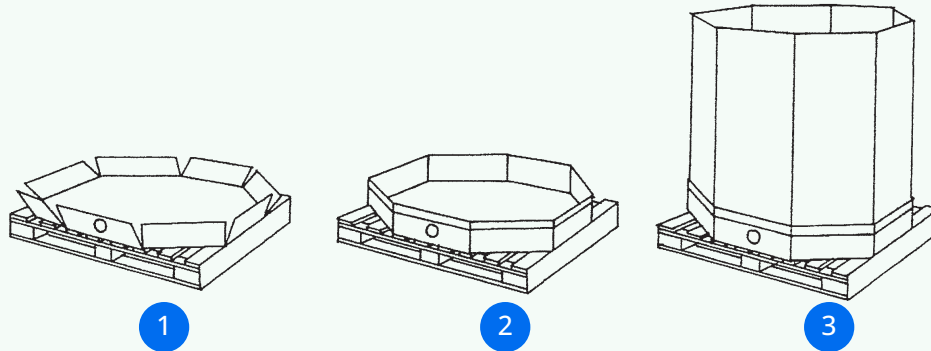

- 1 Make up the bottom tray by folding the flaps inwards and securing with sticky tape on each joint.
- 2 Place on pallet with the discharge hole adjacent to an open edge of the pallet.
- 3 Open out the inner sleeve to form the octagon shape and stand it inside the bottom tray ensuring that the discharge holes are lined up.

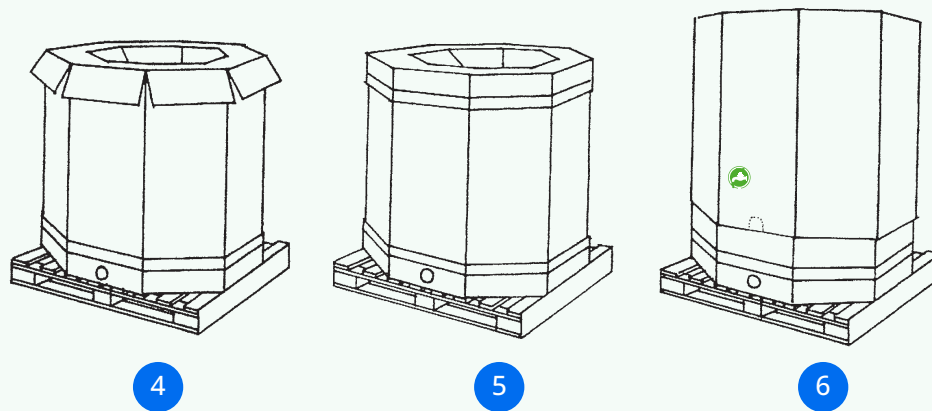

- 4 Make up the top tray in the same manner as the bottom tray.
- 5 Place on the top of the inner sleeve.
- 6 Open out the outer sleeve to form the octagon shape and place over the container, pushing it right down to the pallet once again ensuring that the perforated cut out, lines up with the discharge hole.

Prepare for Filling Instructions

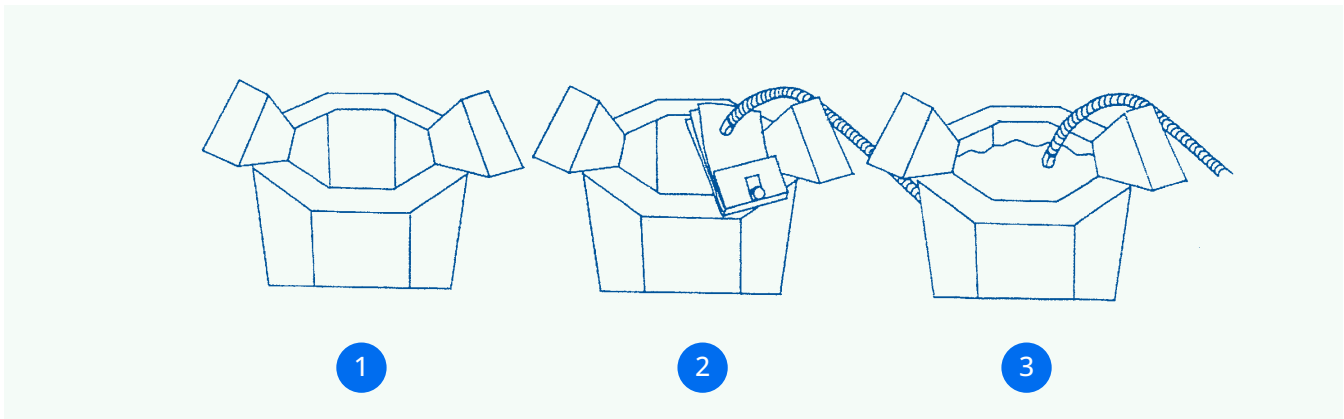

- 1 Attach filling pipe to liner cassette fitment.
- 2 Drop filling pipe and liner cassette into the container.
- 3 Ensure cassette is located to the back of the container and the decant fitment engages into the discharge hole and base tray.

Prepare for Shipping

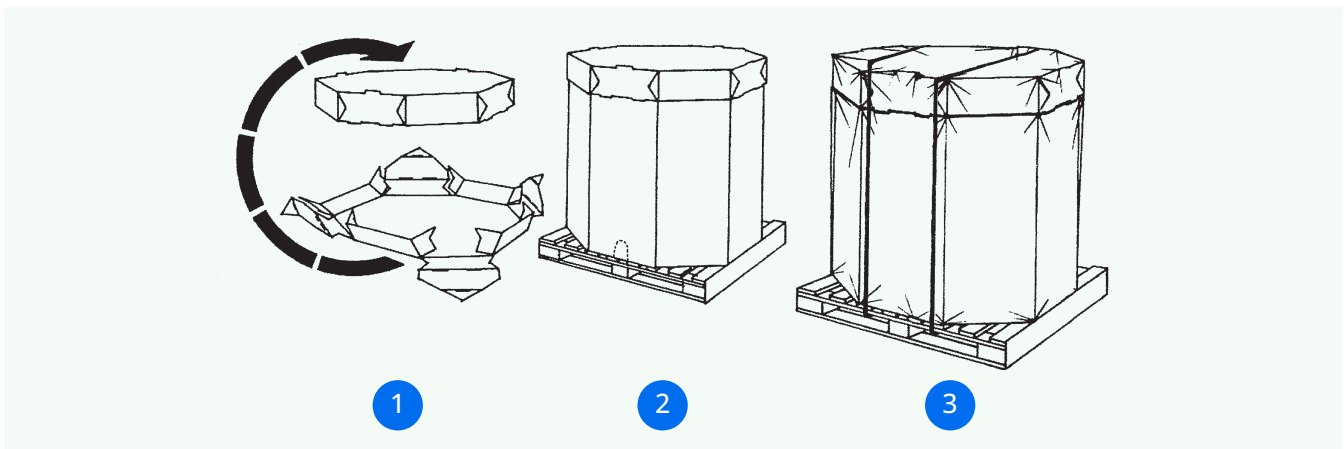

- 1 Make up the lid by folding all creases and locating the tabs in the corresponding slots. Place on top of Liqui-Trip Container.
- 2 Cover with weather proof shroud if required.
- 3 Ensure Liqui-Trip Container is banded twice to pallet prior to moving.

Technical Datasheet

LIQUI-TRIP

VOLUME - Internal Fill Vol.	266.81 gal (1010L)
CAPACITY	2314.85 (1050kg)
PALLET	45.66 x 45.66 (1160x1160)
TARE WEIGHT	88.18 (40kg)
MAX LOAD STACK (Dynamic)	2 high
MAX LOAD STACK (Static)	3 high

DIMENSIONS

IN (MM)

INLET/OUTLET: 2" (50.8)

OUTSIDE DIMENSIONS

Length	45.66 (1160)
Width	45.66 (1160)
Height	45.66 (1160)

INSIDE DIMENSIONS

Length	44.09 (1120)
Width	44.09 (1120)
Height	39.37 (1000)

