

1 2 3 4 5 6

A

B

C

D

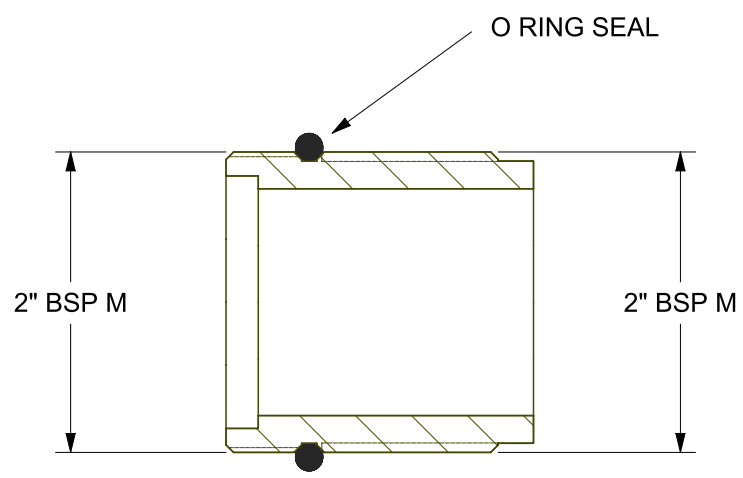
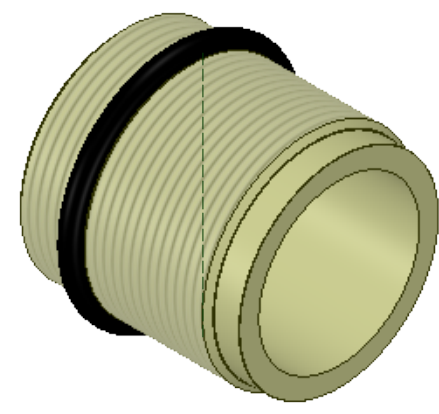
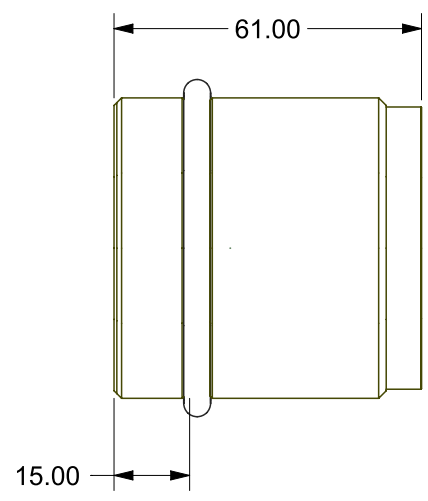

SECTION A-A

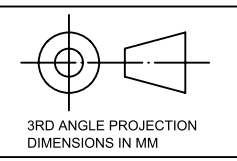
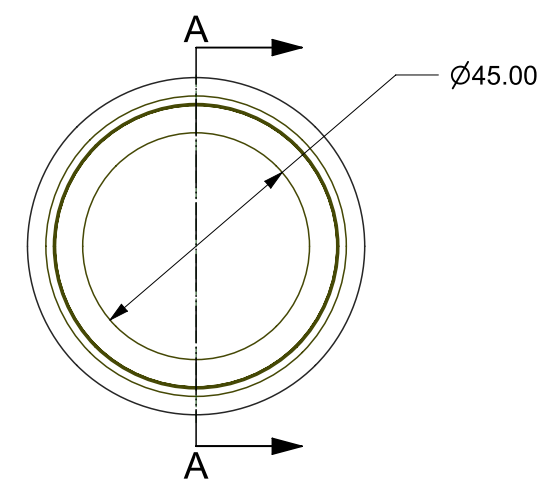

**TOTE SOLUTIONS LTD.**

TITLE  
**2" BSP ADAPTOR/CUTTER PUSHER**

1	FIRST ISSUE	DATE
ZONE	REV No.	REVISION

THIS DRAWING REMAINS THE PROPERTY OF BAILEY WAREHAM LIMITED AND MAY NOT BE REPRODUCED WITHOUT WRITTEN CONSENT

REMOVE ALL SHARP CORNERS 0.3 x 45° TYP.  
ALL FILLET RADII 0.4 MAX. UNLESS OTHERWISE STATED

MATERIAL

TOLERANCES UNLESS OTHERWISE STATED  
OPEN ±0.5  
1 PLACE ±0.1  
2 PLACES ±0.05  
3 PLACES ±0.05  
ANGULAR ±0.25°

SIZE  
**A4**

REV  
**1**

DWG NO  
**TSFVWT207-35**

SCALE  
**2:3**

DATE

SHEET  
**1 OF 2**

1 2 3 4 5 6